

MKIV Jib Reefing & Furling



HEADSAIL HANDLING

PERFORMANCE HEADSAIL HANDLING

Designed for performance racing and cruising sailors, MKIV furling systems are strong, lightweight and aerodynamic, with the performance and features Harken is known for. Longevity, ease of use, and simplicity of installation are crucial components of the design.

These free-rolling systems make all the difference in headsail control, allowing racers and cruisers to quickly furl and reef while maintaining great sail shape and optimal speed. Smoothly unfurl your headsail instead of hoisting a large genoa in light air. Now you can stay off the foredeck during a blow and rely on the furler for 'crew' when sailing shorthanded.

LOW-FRICTION BALL BEARINGS

This strong, lightweight furler features multiple rows of Torlon® ball bearings in high-load areas to minimize friction for smooth furling. Bearings require no lubrication or isolating seals.

Stacked bearing races in the halyard swivel evenly distribute radial and thrust loads to ball bearings; foils turn freely under halyard loads.



BUILT TO LAST

Foils and drum are securely connected with strong robust clamp to handle the high torque loads created when sails are reefed and furled in heavy air.



DURABLE TRIPLE-LOCK FOIL JOINTS

Tough triple-interlock foil joints withstand years of torque loading. Connector and geometric shape interlocks to foil and secures by coating engineered channel system with a syringe-injected adhesive. Screws provide a final lock.



STANDS UP TO THE ELEMENTS

Deep-saturation Hardkote-anodized halyard swivel, line guard, torque tube and bearing races resist the corrosive effects of saltwater and sun and provide long-term wear. The line guard is also powder coated for added corrosion resistance. The drum cap is engineered from tough polymer resin.



EASY REEFING AND FURLING

The large inner spool diameter makes furling easier and a smaller outside drum diameter fits narrow bows or below deck. Independent halyard swivels furl sail center before head and tack for improved sail shape and upwind pointing.

MKIV Jib Reefing & Furling

RACE MODE

Aerodynamic foil's double grooves and stainless steel feeder allow fast hoists, douses and sail changes. Split drum and line guard come off easily use with full-hoist sails.



INSTALLATION IS EASY

MKIV furling systems are designed for owner installation using rod, swage, Norseman®, or Sta-Lok® terminals.

Installs over turnbuckle. C-shaped connectors slip over headstay without feeding wire through connector.

Turnbuckle is accessible for fine tune adjustments by raising the drum.

RIGGING OPTIONS

Multiple Harken toggle options adapt to a variety of turnbuckles. Eye Jaw Toggle flips for fork or tang chainplate installation.

Note: Some headstays will require cutting and shortening to fit Harken toggle. If turnbuckle can be shortened and/or mast raked back, the headstay can remain uncut. Check with professional rigger on stay condition before reusing stay.



Rigging Options

See reverse side of second page



CARBO LEAD BLOCK ASSEMBLIES

Free rolling ball bearing blocks are easy to mount and lead line aft for safe furling from the cockpit. Blocks feature lightweight nylon-resin sideplates densely packed with long-glass fibers. Ball bearing sheave and sideplates UV stabilized with black additive for maximum protection.

The 7403 blocks lead line outboard to keep the sidedeck clear. Mount the 7401 to the bow pulpit. The aft block is a 7402 ratchet block to keep drag on the line to control spooling.



7410.30

7410.31

Rod Adaptor Stud
(sold separately)
7420 -4
7421 -6

Harken Eye/Jaw
Toggle Assembly
(sold separately)
7410.20 3/8
7410.20 7/16

7401

7402

7403

MKIV Unit 0 Typical Boat Length 22' - 30' (6.5 - 9.1 m)

Wire Ø (1 x 19 SS)	Rod Ø	Clevis Pin Ø
3/16", 7/32" (5, 6 mm)	-4 -6 (4.37, 5.03 mm)	3/8", 7/16" (9.5, 11.1 mm)
Headstay Length	Standard 38'7" (11.77 m); max 45'7" (13.9 m)	
Part No.	Description	
7410.10	Furling system	
Toggle Assembly Required - sold separately		
7410.20 3/8	Toggle assembly (eye/jaw) with 3/8" (9.5 mm) clevis pin	
7410.20 7/16	Toggle assembly (eye/jaw) with 7/16" (11.1 mm) clevis pin	
Optional Parts		
7410.30	Extra 7' (2.13 m) luff foil extrusion	
7410.31	Extra 6 1/2" (165 mm) connector with bushings	
7420 -4	-4 Rod adaptor stud (thread Ø UNF 7/16")*	
7421 -6	-6 Rod adaptor stud (thread Ø UNF 7/16")*	
884	Snap shackle for tack or head (each shackle)	
944	Halyard restrainer (use only when required)	
7401	40 mm Carbo block stanchion lead block assembly	
7402	57 mm Carbo ratchet block stanchion lead block assembly	
7403	29 mm Outboard stanchion lead block assembly	
7404	Lead block kit: 3 x 7403/1 x 7402/1 x 7401/1 cleat	

*Use with conventional turnbuckle



7404



884

944

HARKEN

MKIV Unit 1 Typical Boat Length 28' - 36' (8.3 - 11 m)

Wire Ø (1 x 19 SS)	Rod Ø	Clevis Pin Ø
1/4", 9/32", 5/16" (6, 7, 8 mm)	-8 -10 -12 (5.72, 6.35, 7.14 mm)	1/2", 5/8" (12.7, 15.9 mm)
Headstay Length	Standard 45'11" (13.99 m); max 52'11" (16.12 m)	
Part No.	Description	
7411.10	Furling system	
Toggle Assembly Required - sold separately		
7411.20 1/2	Eye/Jaw reversible toggle assembly with 1/2" (12.7 mm) clevis pin	
7311.20 1/2	Jaw/Jaw toggle assembly with 1/2" (12.7 mm) clevis pin	
7311.20 5/8	Stud/Jaw toggle assembly with 5/8" (15.9 mm) clevis pin	
7311.21 1/2	Long link plate with toggle assembly with 1/2" (12.7 mm) clevis pin	
7311.21 5/8	Long link plate with toggle assembly with 5/8" (15.9 mm) clevis pin	
Optional Parts		
7411.30	Extra 7' (2.13 m) luff foil extrusion	
7411.31	Extra 7" (178 mm) connector with bushings	
7422 -8	-8 Rod adaptor stud (thread Ø UNF 1/2")*	
7423 -10	-10 Rod adaptor stud (thread Ø UNF 1/2")*	
7424 -12	-12 Rod adaptor stud (thread Ø UNF 5/8")*	
944	Halyard restrainer (use only when required)	
7401	40 mm Carbo block stanchion lead block assembly	
7402	57 mm Carbo ratchet block stanchion lead block assembly	
7403	29 mm Outboard stanchion lead block assembly	
7404	Lead block kit: 3 x 7403/1 x 7402/1 x 7401/1 cleat	

*Use with conventional turnbuckle.

MKIV Unit 2 Typical Boat Length 35' - 46' (10.6 - 14.2 m)

Wire Ø (1 x 19 SS)	Rod Ø	Clevis Pin Ø
5/16", 3/8" (8, 10 mm)	-12 -17 -22 (7.14, 8.38, 9.53 mm)	5/8", 3/4" (15.9, 19.1 mm)
Headstay Length	Standard 60'4" (18.38 m); max 67'4" (20.51 m)	
Part No.	Description	
7412.10	Furling system	
Toggle Assembly Required - sold separately		
7412.20 5/8	Eye/Jaw reversible toggle assembly with 5/8" (15.9 mm) clevis pin	
7312.20 5/8	Jaw/Jaw toggle assembly with 5/8" (15.9 mm) clevis pin	
7312.20 3/4	Stud/Jaw toggle assembly with 3/4" (19.1 mm) clevis pin	
7312.21 5/8	Long link plate with toggle with 5/8" (15.9 mm) clevis pin	
7312.21 3/4	Long link plate with toggle with 3/4" (19.1 mm) clevis pin	
Optional Parts		
7412.30	Extra 7' (2.13 m) luff foil extrusion	
7412.31	Extra 9" (229 mm) connector with bushings	
7424 -12	-12 Rod adaptor stud (thread Ø UNF 5/8")*	
7425 -17	-17 Rod adaptor stud (thread Ø UNF 5/8")*	
7426 -22	-22 Rod adaptor stud (thread Ø UNF 3/4")*	
885	Snap shackle for tack/head (each shackle)	
945	Halyard restrainer (use only when required)	
7401	40 mm Carbo block stanchion lead block assembly	
7402	57 mm Carbo ratchet block stanchion lead block assembly	
7403	29 mm Outboard stanchion lead block assembly	
7404	Lead block kit: 3 x 7403/1 x 7402/1 x 7401/1 cleat	

*Use with conventional turnbuckle

MKIV Unit 3 Typical Boat Length 45' - 60' (13.7 - 18.3 m)

Wire Ø (1 x 19 SS)	Rod Ø	Clevis Pin Ø
7/16", 1/2" (11, 12 mm)	-22, -30 (9.53, 11.10 mm)	3/4", 7/8" (19.1, 22.2 mm)
Headstay Length	Standard 75'1" (22.88 m); max 82'1" (25.02 m)	
Part No.	Description	
7413.10	Furling system	
Toggle Assembly Required - sold separately		
7413.20 3/4	Eye/Jaw reversible toggle assembly with 3/4" (19.1 mm) clevis pin	
7413.20 7/8	Eye/Jaw reversible toggle assembly with 7/8" (22.2 mm) clevis pin	
7312.21 3/4	Long link plate with toggle with 3/4" (19.1 mm) clevis pin	
7312.21 7/8	Long link plate with toggle with 7/8" (22.2 mm) clevis pin	
Optional Parts		
7413.30	Extra 7' (2.13 m) luff foil extrusion	
7413.31	Extra 9 3/4" (248 mm) connector with bushings	
7426 -22	-22 Rod adaptor stud (thread Ø UNF 3/4")*	
7427 -30	-30 Rod adaptor stud (thread Ø UNF 7/8")*	

*Use with conventional turnbuckle

7411.30
7412.30
7413.30

7411.31
7412.31
7413.31

Harken Eye/Jaw Toggle Assembly (sold separately)

7411.20 1/2
7412.20 5/8
7413.20 3/4
7413.20 7/8

Harken Jaw/Jaw Toggle Assembly (sold separately)

7311.20 1/2
7312.20 5/8

Harken Long Link Plate w/Toggle (sold separately)

7311.21 1/2
7311.21 5/8
7312.21 5/8
7312.21 3/4
7313.21 3/4
7313.21 7/8

Harken Jaw/Jaw Toggle Assembly (sold separately)

7311.20 5/8
7312.20 3/4

Rod Adaptor Stud (sold separately)

7422 -8
7423 -10
7424 -12
7425 -17
7426 -22
7427 -30



HARKEN

MKIV & Cruising Toggle Options

Use these rigger supplied options to fit Harken toggles shown below.
Harken Toggle assemblies sold separately.

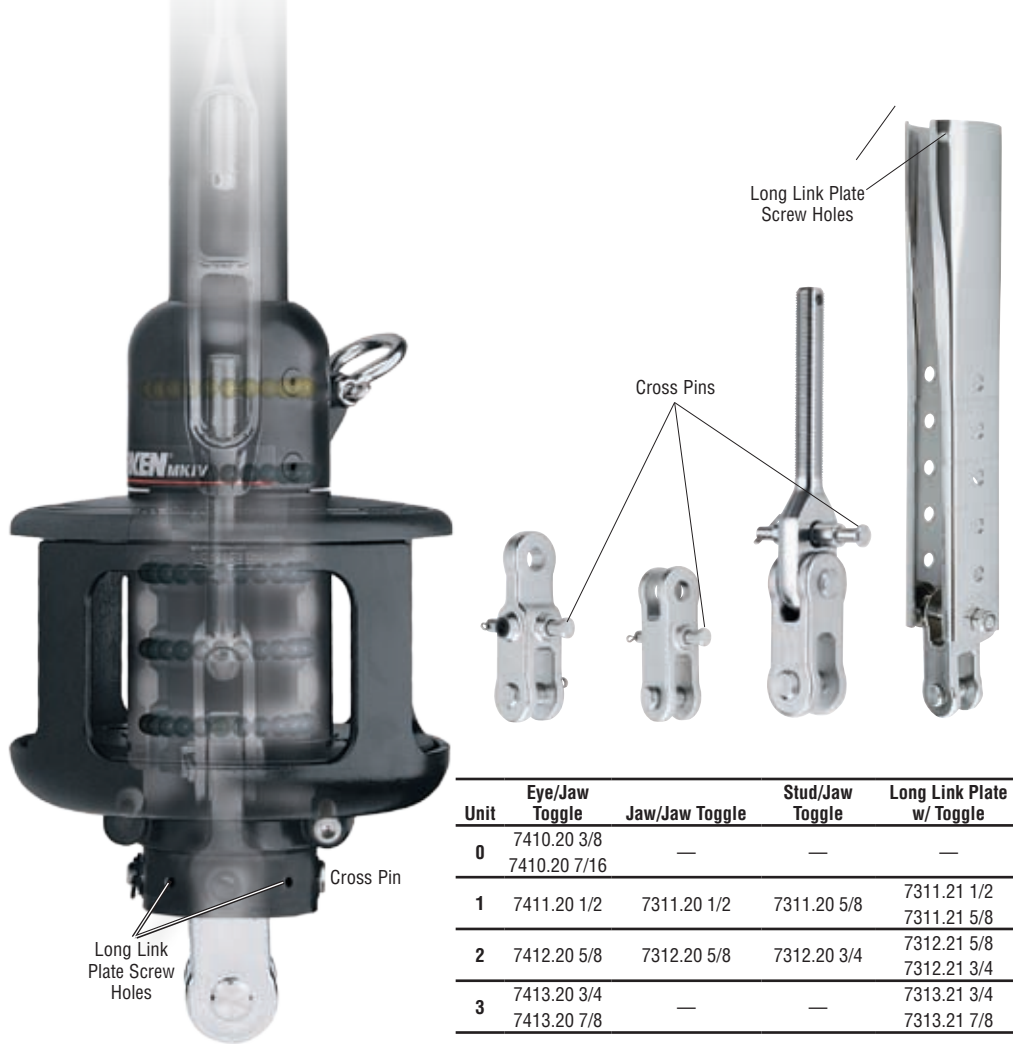

Unit	Eye/Jaw Toggle	Jaw/Jaw Toggle	Stud/Jaw Toggle	Long Link Plate w/ Toggle
0	7410.20 3/8	—	—	—
	7410.20 7/16	—	—	—
1	7411.20 1/2	7311.20 1/2	7311.20 5/8	7311.21 1/2 7311.21 5/8
	7412.20 5/8	7312.20 5/8	7312.20 3/4	7312.21 5/8 7312.21 3/4
3	7413.20 3/4	—	—	7313.21 3/4
	7413.20 7/8	—	—	7313.21 7/8

Model	Toggle Part No.	Description	Clevis Pin Ø		Fits Unit	Furler Part No.
			in	mm		
MKIV	7410.20 3/8	Eye/Jaw (reversible)	3/8	9.5	0	7410.10
	7410.20 7/16	Eye/Jaw (reversible)	7/16	11.1	0	7410.10
	7411.20 1/2	Eye/Jaw (reversible)	1/2	12.7	1	7411.10
	7311.20 1/2	Jaw/Jaw	1/2	12.7	1	7411.10
	7311.20 5/8	Stud/Jaw	5/8	15.9	1	7411.10
	7311.21 1/2	Long link plate w/ toggle	1/2	12.7	1	7411.10
	7311.21 5/8	Long link plate w/ toggle	5/8	15.9	1	7411.10
	7412.20 5/8	Eye/Jaw (reversible)	5/8	15.9	2	7412.10
	7312.20 5/8	Jaw/Jaw	5/8	15.9	2	7412.10
	7312.20 3/4	Stud/Jaw	3/4	19.1	2	7412.10
	7312.21 5/8	Long link plate w/ toggle	5/8	15.9	2	7412.10
	7312.21 3/4	Long link plate w/ toggle	3/4	19.1	2	7412.10
	7413.20 3/4	Eye/Jaw (reversible)	3/4	19.1	3	7413.10
	7413.20 7/8	Eye/Jaw (reversible)	7/8	22.2	3	7413.10
CRUISING	7313.21 3/4	Long link plate w/ toggle	3/4	19.1	3	7413.10
	7313.21 7/8	Long link plate w/ toggle	7/8	22.2	3	7413.10
	7411.20 1/2	Eye/Jaw (reversible)	1/2	12.7	1	7311.10
	7311.20 1/2	Jaw/Jaw	1/2	12.7	1	7311.10
	7311.20 5/8	Stud/Jaw	5/8	15.9	1	7311.10
	7311.21 1/2	Long link plate w/ toggle	1/2	12.7	1	7311.10
	7311.21 5/8	Long link plate w/ toggle	5/8	15.9	1	7311.10
	7412.20 5/8	Eye/Jaw (reversible)	5/8	15.9	2	7312.10
	7312.20 5/8	Jaw/Jaw	5/8	15.9	2	7312.10
	7312.20 3/4	Stud/Jaw	3/4	19.1	2	7312.10
	7312.21 5/8	Long link plate w/ toggle	5/8	15.9	2	7312.10
	7312.21 3/4	Long link plate w/ toggle	3/4	19.1	2	7312.10

Rigger Supplied

Harken

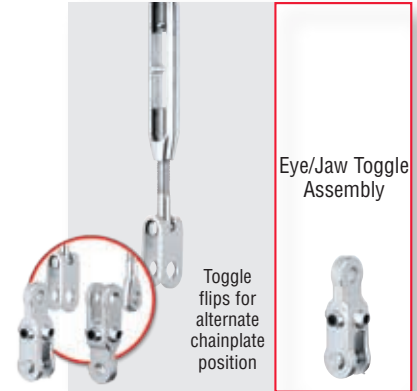

Eye/Jaw Toggle Assembly



Jaw/Jaw Toggle Assembly

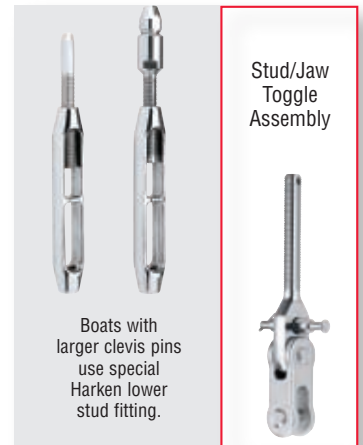

Stud/Jaw Toggle Assembly



Long Link Plate w/ Toggle

HARKEN